

## TITLE III

### Operating Departments

#### Chapter 1

#### Airport

Sec. 3-1-1	Definitions
Sec. 3-1-2	General provisions
Sec. 3-1-3	Aircraft operations
Sec. 3-1-4	Motor vehicles
Sec. 3-1-5	Aircraft refueling
Sec. 3-1-6	Fire regulations
Sec. 3-1-7	Personal conduct
Sec. 3-1-8	Violations; penalties
Sec. 3-1-9	Airport security
Sec. 3-1-10	Abandonment
Sec. 3-1-11	Taxes
Sec. 3-1-12	Unlawful business interest
Sec. 3-1-13	Sale of real property
Sec. 3-1-14	Combined service fee

#### Chapter 2

#### Fire Department

##### *Article I*

##### *Fire Department*

Sec. 3-2-1	Firefighters; duties
Sec. 3-2-2	Fire Chief; powers and duties
Sec. 3-2-3	Loitering
Sec. 3-2-4	Apparatus; uses; maintenance
Sec. 3-2-5	Interfering with hose, hydrant
Sec. 3-2-6	Turning water on persons; needlessly handling hose

##### *Article II*

##### *International Fire Code*

Sec. 3-2-21	International Fire Code; adoption by reference
Sec. 3-2-22	Division of Fire Prevention; establishment; supervisor
Sec. 3-2-23	Dual coverage; most restrictive governs
Sec. 3-2-24	Reference to other codes
Sec. 3-2-29	Vehicles transporting hazardous materials including flammable liquids; inspections; approval
Sec. 3-2-30	Routing; local delivery
Sec. 3-2-31	Existing buildings; effective date
Sec. 3-2-32	High-rise buildings; compliance
Sec. 3-2-33	International Fire Code; fireworks
Sec. 3-2-34	Permit fees for operational and construction permits required by International Fire Code
Sec. 3-2-38	Smoking in various establishments; rooms permissible; notice
Sec. 3-2-50	Open burning; incinerators; ashes
Sec. 3-2-51	Definitions
Sec. 3-2-52	Unlawful to sell or use certain types of fireworks
Sec. 3-2-53	Items not considered fireworks; permits for sale
Sec. 3-2-54	Regulations and permits for display
Sec. 3-2-55	Bonds and insurance
Sec. 3-2-56	Interpretation
Sec. 3-2-57	Seizure of fireworks

Sec. 3-2-58 Unlawful conduct and criminal penalties; revocation of permits; other enforcement  
Sec. 3-2-59 Board of Appeals  
Sec. 3-2-60 Additional modifications to International Fire Code

## CHAPTER 1

### Airport

#### Sec. 3-1-1. Definitions.

(a) *Airport* means the Pueblo Memorial Airport, City of Pueblo, Pueblo County, Colorado, including all land and improvements owned, controlled or operated and maintained by the City in connection with its operation of said airport. For purposes of convenience, the land area of the airport is divided into two (2) parts, the industrial-recreational area and the aviation area.

(b) *Industrial-recreational area* means that portion of the airport south of American Avenue as shown on the master map of the airport extended easterly to the east boundary of the airport and extended westerly to the west boundary of the airport, together with all improvements thereon; excepting that parkway extending from the terminal building on the north to the Santa Fe Railroad property line on the south and fifty (50) feet east of the northbound lanes and fifty (50) feet west of the southbound lanes of Keeler Parkway.

(c) *Aviation area* means that portion of the airport lying north of American Avenue extended easterly to the east boundary of the airport and extended westerly to the west boundary of the airport and is divided into five (5) parts:

(1) The operations control area, consisting of administration and terminal buildings, weather bureau building, tower, hangars, warehouses and similar buildings, together with all lands appurtenant and immediately adjacent thereto; also including the parkway;

(2) The ramp and apron area, comprising that area covered by concrete, whether or not resurfaced, lying immediately north of the operations control area;

(3) The landing area comprising the runways, taxiways, approach areas, access routes and crash roads;

(4) The air operations area, consisting of both the ramp and apron area and the landing area; and

(5) The air side area, consisting of and including that portion of the operations control area used for storing, parking or movement of aircraft and the air operations area.

(d) *Director* means the Director of Aviation or person in charge of the airport for the City, his or her assistant or duly authorized representative.

(e) *Fire Chief* means the head of the Pueblo Fire Department, or in his or her absence, the senior Pueblo Fire Department officer present at the airport.

(f) *F.A.A.* means the Federal Aviation Administration.

(g) *Aircraft* means any and all contrivances used now or in the future for the navigation of or flight in air or space, including but not limited to airplanes, airships, sail planes, gliders, helicopters, amphibians, etc.

(h) *Air carriers* means scheduled or nonscheduled aircraft operating under a certificate issued by the Civil Aeronautics Board.

(i) *Airline personnel* means all officers, agents and employees of air carriers.

(j) *General aviation* means all aircraft that are not air carriers or military.

(k) *Vehicle* means all vehicles and motorized equipment moving on the ground propelled by power including muscular power, and including trailers and coaches but excepting aircraft while taxiing and construction equipment being used in actual construction in progress on the airport. (1957 Code, §7-1; Ord. No. 3623, 11-13-72)

### **Sec. 3-1-2. General provisions.**

(a) *Liability.* The privilege of using the airport and its facilities shall be conditioned on the assumption of full responsibility and risk by the user thereof, and he or she shall release, hold harmless and indemnify the City, its officers, employees and tenants from any liability or loss resulting from such use as well as against claims of third parties so using the airport.

(b) *Scope.* All users of and persons on the airport shall be governed by this Code and regulations and procedures that will from time to time be promulgated by the Director. It shall be the duty of the Director to enforce provisions of this Code and regulations adopted by the City.

(c) *Commercial Operations.* It shall be unlawful for any person to conduct any business on the airport without having first obtained a written contract, lease or permit from the City. For the purposes of this Section, the following activities shall constitute conducting businesses on the airport:

(1) The sale of any goods, wares, merchandise or services.

(2) The advertising of any business by word of mouth, billboard or sign on the airport excepting signs painted on or fixed to a motor vehicle.

(3) The use of an aircraft on the airport in the transportation of persons or property for hire.

(4) The rental of aircraft for hire.

(5) Maintenance, inspections and oil changes on any aircraft by any person receiving compensation therefor.

(6) The transportation of persons or property by a motor vehicle where the person providing the transportation receives compensation.

(d) *Flying Clubs.* Flying club aircraft must be owned and operated on a nonprofit basis or as a nonprofit Colorado corporation, and each club member must be a bona fide owner of a part of the

aircraft or a share in the corporation. The club may not derive greater revenue from the use of aircraft than the amount necessary for the operation, maintenance and replacement of the aircraft and will file and keep up-to-date with the Director a list of the membership. If the Director has reason to believe a club is being operated so that it falls under the "commercial" classification, he or she shall so notify the club. If the club fails to remedy the condition complained of, the Director shall reclassify the aircraft. Thereafter, the club shall be classified as commercial. The Director shall have authority to deny the use of a club classification to any group failing to meet the requirements outlined herein.

(e) Soliciting. It shall be unlawful for any person to solicit funds for any purpose on the airport without having first obtained permission from the Director.

(f) Restricted Areas. It shall be unlawful for any person to enter any restricted area that is posted as closed to the public, except employees and persons authorized by the Director.

(g) Sanitation. It shall be unlawful for any person to place any garbage, refuse and other waste material in any receptacle except as shall be specifically provided for such purpose.

(h) Conduct of Business. It shall be the responsibility of tenants to conduct their business in accordance with their agreement with the City and this Chapter.

(i) Suspension of Operations. The airport shall be open for public use at all hours of the day and night subject to restrictions due to inclement weather as determined by the F.A.A. conditions of the landing area, presentation of special events and like causes as may be determined by the Director. (1957 Code, §7-2; Ord. No. 4880, 7-27-81; Ord. No. 7082 §1, 11-24-03)

### **Sec. 3-1-3. Aircraft operations.**

(a) Aircraft shall be operated and maintained at all times in accordance with applicable F.A.A. and C.A.B. regulations.

(b) Parking and storage of aircraft will be accomplished only in areas designated by the Director.

(c) No aircraft shall be parked, stored, washed or repaired at the airport except in the areas designated by the Director for such use, or left unattended on the main ramp except with written permission of the Director.

(d) At the request of the Director, the operator of any aircraft on the airport shall move the aircraft from the place where it is parked or stored to any other place designated on the airport. If the operator fails or refuses to comply, the Director may cause the aircraft to be towed to such place at the operator's expense and without liability for damage which may result in the course of such moving.

(e) Except in emergency, no aircraft equipped with a tail skid in place of the tail wheel will land or take off from a paved surface of the airport.

(f) In the event of an accident, the Director may move damaged aircraft from the landing areas, ramps, aprons or other areas at the expense of the owner without liability for damage which may result in the course of such moving.

(g) The pilot of an aircraft involved in an accident on or near the airport causing personal injury or property damage shall report such accident to the Director. In the event that he or she is unable to make such report, the owner or his or her agent and witnesses can accomplish such report.

(h) The Director shall have the authority to detain any aircraft for nonpayment of charges due the City.

(i) Aircraft will register in accordance with the procedures established by the Director.

(j) Ground operation of aircraft including taxi run-up and use of preferential runways will be in accordance with procedures established by the Director.

(k) Special events such as air shows, air races, fly-ins, sky diving and all events requiring the general use of the airport, other than normal or routine airport traffic, shall be held only upon prior approval of the Director, and on such dates, in such areas and upon terms and conditions as shall be specified by the Director.

(l) For the purpose of prosecution for failure to comply with any provision of this Chapter, in the absence of evidence to the contrary, it shall be presumed that the owner of any aircraft was the operator of such aircraft. (1957 Code, §7-3; Ord. No. 3170, 1, 1-8-68)

#### **Sec. 3-1-4. Motor vehicles.**

(a) The traffic ordinances of the City and the Model Traffic Code for Colorado Municipalities apply to the streets, roads and parking areas on the airport.

(b) The Director, or employees of the airport designated by the Director, shall be empowered to enforce all traffic rules and regulations.

(c) It shall be unlawful for any person to fail or refuse to comply with the unlawful orders of the Director or any employee of the airport designated by him or her, a police officer or member of the Fire Department, at the scene of a fire or accident.

(d) It shall be unlawful for any person to operate a motor vehicle on the landing ramp and apron areas except as authorized by the Director.

(e) It shall be unlawful for any person to park a motor vehicle, for loading, unloading or any other purpose, on the airport except in the areas specifically established for parking and designated as such by signs, lines or other means.

(f) It shall be unlawful for any person to abandon any motor vehicle on the airport. The Director shall have the authority to tow or otherwise move motor vehicles which are parked by their owners or operators on the airport in violation of the regulations of the airport, at the owner's expense and without liability for damage which may result in the course of such moving and to detain the motor vehicles until all such charges are paid.

(g) It shall be unlawful for any person to park any vehicle in any manner that will obstruct fire gates on entrances to the airport. In all cases vehicular traffic shall yield the right-of-way to aircraft. (1957 Code, §7-4; Ord. No. 3170, §1, 1-8-68)

**Sec. 3-1-5. Aircraft refueling.**

It shall be unlawful for any person to:

- (1) Fuel or defuel any aircraft while the engine is running or while the aircraft is in a hangar or an enclosed area.
- (2) Conduct any fueling operation unless the aircraft is grounded by an approved method.
- (3) Smoke or light an open flame within fifty (50) feet of any fueling operation.
- (4) Operate electrical or radio equipment during fueling operations.
- (5) Start any aircraft when there is fuel on the ground under or near the aircraft. (1957 Code, §7-5)

**Sec. 3-1-6. Fire regulations.**

(a) It shall be unlawful for any person to smoke or light an open flame in locations that are posted and within fifty (50) feet of fuel trucks or fuel loading stations.

(b) It shall be unlawful for any person to start an open fire any place on the airport without permission of the Aviation Director.

(c) It shall be unlawful for any person to stock or store any material or equipment in such a manner as to constitute a fire hazard.

(d) It shall be unlawful for any person to use flammable, volatile liquids in the cleaning of aircraft, aircraft engines, propellers and appliances unless such cleaning operations are conducted at locations designated by the Director.

(e) Tenants shall provide metal containers for the storage of oily waste rags and other inflammable materials and shall maintain hangar floors, gasoline pits and trucks cleaned and free of excess gasoline, grease and other inflammables and shall provide suitable fire extinguishers and equipment maintained in good condition as recommended by the Fire Chief.

(f) Tenants of the industrial area shall, at their own expense, keep the demised premises clean, neat, safe and orderly at all times, free of waste, rubbish, debris and fire hazards and shall provide a complete and proper arrangement for the sanitary handling and disposal of all trash, garbage and other refuse resulting from his or her activities at the airport.

(g) A tenant as lessee under a fixed base operator's lease agreement with the City for use of the airport or any part thereof may construct, operate and maintain its own permanent aviation fuel

storage facility on its leased premises at the airport at a place remote and separate from the aviation area and occupied buildings upon the following conditions:

(1) The location of the facility and the plans and specifications therefor shall be approved by the Director of Aviation and Fire Chief.

(2) The tenant shall enter into an indemnification agreement with the City indemnifying and saving harmless the City, its officers, agents and employees from all claims for damages to property and injury or death to persons arising out of, or resulting directly or indirectly from, the use, construction or maintenance of the facility or the storage or dispensing of fuel therefrom or the quality or condition of the fuel and keep in force liability insurance insuring the tenant's obligation hereunder and the City in amounts not less than one million dollars (\$1,000,000.00) for property damage and one million dollars (\$1,000,000.00) for personal injury or death.

(3) The tenant shall establish accepted and approved procedures for and continuously monitor fuel quality control. The tenant shall each week submit to the Director a written report of monitoring activities conducted by the tenant during the prior week.

(4) The tenant shall pay to the City as additional rent under its fixed base operator's lease agreement an amount equal to seven cents (\$.07) for each gallon of aviation fuel delivered to said facility, which rent shall be paid monthly.

(5) The facility shall be removed and the airport property shall be restored to its former condition within fifteen (15) days after termination of the tenant's fixed base operator's lease agreement, or at the option of the City, the facility shall upon such termination become the property of the City free of all liens and encumbrances.

(6) No temporary aviation fuel storage facility shall be located on a tenant's leased premises or used by an tenant at the airport.

(7) All fuel delivered to an approved facility shall be measured by meters approved by the Director and installed and maintained by the tenant at its costs. The meters shall be read daily by the tenant, and the tenant shall weekly submit to City a written report thereof together with copies of invoices for all fuel delivered to the facility during the prior week.

(8) Fuel delivered to an approved facility shall not be sold to other tenants at the airport or to persons not doing business at the airport and shall only be sold at retail to the tenant's customers.

(9) A tenant, after installation of an approved facility, shall not thereafter be entitled to purchase aviation fuel from the City. Such installation by a tenant shall constitute a complete waiver of the tenant's rights, if any, to purchase from or be allocated a portion of aviation fuel purchased by the City. The City may however, sell aviation fuel to the tenant in such amounts and at such times as the City in its sole discretion shall determine.

(10) All aviation fuel sold or delivered from such facilities shall be at least equal to the standards for Grade 80, Grade 100LL or Grade 100 aviation gasolines standards for Jet A or Jet A-1 or equivalent aviation turbine fuels as published by the American Society for Testing and Materials in its most current revised publication.

(11) A violation of any provision of this Subsection (g) by a tenant shall constitute grounds to terminate the tenant's fixed base operator's lease agreement with City. (1957 Code, §7-6; Ord. No. 4899, 9-14-81)

**Sec. 3-1-7. Personal conduct.**

(a) It shall be unlawful for any person to destroy, injure, deface or disturb in any way any building, sign, equipment, marker or other structure, tree, flower, lawn or other property on the airport; or make any excavations on the airport; or willfully abandon any personal property on the airport.

(b) It shall be unlawful for any person to enter the terminal building or the airport with a dog or other animal unless the dog or animal is restrained by leash or is properly confined.

(c) All persons using the airport must refrain from littering the premises, and any trash or waste material is to be placed only in containers provided for such use.

(d) All of the offense ordinances of the City, being Chapter 1 of Title XI of this Code and as the same may hereafter be amended, shall apply to the airport. It shall be unlawful for any person to violate any section or provision of said Chapter 1 of Title XI while on the airport. (1957 Code, §7-7; Ord. No. 3623, 11-13-72; Ord. No. 4901, 9-28-81)

**Sec. 3-1-8. Violations; penalties.**

Any person violating any of the provisions of this Chapter or any of the rules and regulations adopted pursuant thereto, or any amendments or additions thereto, shall be punished as prescribed in Section 1-2-1 of this Code. (1957 Code, §7-8)

**Sec. 3-1-9. Airport security.**

(a) It shall be unlawful for any unauthorized person to enter the air side area of the airport in violation of any posted notice restricting access thereto.

(b) It shall be unlawful for any tenant of airport property or any agent or employee of such tenant to permit or allow any unauthorized person to enter the air side area of the airport in violation of any posted notice restricting access thereto.

(c) It shall be unlawful and shall constitute grounds for immediate termination of a tenant's lease of airport property for any tenant of airport property or any agent or employee of such tenant to fail or refuse to close and lock all gates under the control of the tenant or located upon the tenant's leased premises leading into the air side area of the airport when not in actual and authorized use by such tenant or his or her agents or employees. (Ord. No. 3623, 11-13-72)

**Sec. 3-1-10. Abandonment.**

If a lessee or user of airport real property or improvements thereon fails for any reason to actively and continuously conduct and engage in business and activities permitted at the airport for a period of one hundred twenty (120) days or longer, the City may terminate and cancel the lease, contract or

permit under which the lessee or user occupies the property or improvements or conducts business or activities at the airport notwithstanding any provision therein to the contrary. (Ord. No. 5069, 7-25-83)

**Sec. 3-1-11. Taxes.**

If a lessee or user of airport real property or improvements thereon shall become subject to taxation pursuant to any statute or ordinance, such lessee or user shall pay when due all such taxes assessed against the lessee or user. Failure to timely pay such taxes shall constitute a default under such lessee's or user's lease or contract with the City and be grounds for immediate termination of such lease or contract by the City, notwithstanding any provision therein to the contrary. (Ord. No. 5069, 7-25-83; Ord. No. 5679, 5-13-91)

**Sec. 3-1-12. Unlawful business interest.**

It shall be unlawful for any person, firm or corporation, or any officer, director, shareholder, partner or manager thereof, conducting business or engaging in any activity on the aviation area of the airport under a written lease, contract or permit with the City to, directly or indirectly, own or have any interest, whether financial or otherwise, in any business or activity conducted on the aviation area of the airport other than the business or activity specifically authorized by such lease, contract or permit at the location specified therein. A violation of this Section by any person, firm or corporation, or any officer, director, shareholder, partner or manager thereof shall constitute grounds for immediate termination of the lease, contract or permit of such person, firm or corporation, notwithstanding anything contained therein to the contrary. (Ord. No. 5358, 10-27-86)

**Sec. 3-1-13. Sale of real property.**

The City Council is authorized to sell and transfer, by resolution, any real property located in the industrial-recreational area of the airport for such purposes and upon such terms and conditions as the City Council shall determine. (Ord. No. 6037, 11-27-95)

**Sec. 3-1-14. Combined service fee.**

(a) As used in this Section, the following words shall have the following meanings:

(1) *Developed property* means and includes all the land owned by a person or entity other than the City which has been developed by constructing one (1) or more buildings on any portion thereof.

(2) *Occupant* means a tenant in possession of the developed property.

(b) There is imposed upon all owners and occupants of developed property located in the Pueblo Memorial Airport Industrial Park a fee and charge in reimbursement to the City for providing the following services to the developed property, to wit: fire protection, public street maintenance, including landscaping and storm drainage facilities, and street lighting (the "Services").

(c) The fee and charge for services shall be known as the Combined Service Fee and is hereby fixed and established in the following monthly amounts during the following years for each acre of developed property located in the Pueblo Memorial Airport Industrial Park:

<i>Year</i>	<i>Monthly Fee Per Acre</i>
2004 (July – December)	58.75
2005 and each year thereafter	41.66

(d) The revenue from the Combined Service Fee shall be exclusively dedicated to and used for the payment of the direct and indirect cost of providing the Services.

(e) Monies paid to the City by Pueblo County, Colorado, for the provision of fire protection services at the Pueblo Memorial Airport Industrial Park shall be allocated and applied to the Combined Service Fee, and the pro-rata share of such monies shall be credited against the Combined Service Fee established in Subsection (c).

(f) All owners and occupants of developed property located in the Pueblo Memorial Airport Industrial Park shall pay the monthly Combined Service Fee in advance on or before the 15th day of each calendar month commencing with the month of June 2004. If the occupant shall pay the Combined Service Fee, such payment shall relieve the owner from such obligation, but the City shall not be required to look to any person other than the owner to pay the Combined Service Fee. All unpaid Combined Service Fees shall accrue interest at the rate of one percent (1%) per month until paid in full.

(g) If the Combined Service Fee is not timely paid, the Director of Aviation shall cause to be given to the owner and occupant of the developed property a notice of disconnection stating the amount of the due and unpaid Combined Service Fee and interest, describing the property served and the Combined Service Fee and advising the owner and occupant of the developed property that if the due and unpaid Combined Service Fee and interest remain unpaid for a period of sixty (60) days after the date of such notice, the developed property and improvements thereon will be disconnected from the Services and the developed property and improvements thereon will no longer receive the Services. Such notice may be given by personal service or by first class mail or, if the developed property is vacant or if the owner of the developed property cannot be located after reasonable efforts, by posting such notice in a conspicuous place on the developed property or improvements located thereon. If notice is given by mail, notice shall be deemed given five (5) days after the date of mailing. If notice is given by posting, notice shall be complete five (5) days from the date of posting. If the owner or occupant of the developed property fails, neglects or refuses to pay in full all due and unpaid Combined Service Fees and interest described in the notice and which have accrued thereafter, within sixty (60) days after the date of the notice, the Director of Aviation shall cause the developed property and improvements thereon to be disconnected from the Services, and no Service shall thereafter be provided to the developed property or improvements thereon unless and until all delinquent Combined Service Fees and interest have been paid in full.

(h) Neither the imposition nor payment of the Combined Service Fee shall in any manner obligate the City to continue to furnish and provide the Services. The City may, from time to time,

reduce, modify, eliminate, add to or substitute any or all of the Services. The City Council may by resolution modify, increase or decrease the Combined Service Fee, provided that the Combined Service Fee shall be reasonably related to the overall cost (direct and indirect costs) of the Services. The City's cost may include the cost of equipment and capital improvements amortized over their useful life.

(i) All unpaid Combined Service Fees plus interest shall be a charge against the owner of the developed property and shall be treated as a debt due the City from the owner. The unpaid Combined Service Fees, plus interest and cost of collection, including reasonable attorney fees, may be collected from the owner of the developed property in an action at law.

(j) The Combined Service Fee fixed and established by Subsection (c) above constitutes and shall be deemed to constitute the Combined Service Fee and the amount thereof payable by owners of real property in the Pueblo Memorial Airport Industrial Park pursuant to agreements, contracts, deeds and covenants among such owners and the City. Payment of the Combined Service Fee for developed property pursuant to this Section shall relieve such owner from the obligation to pay a combined service fee under any agreement, contract, deed or covenant between such owner and the City. (Ord. No. 7144, 5-10-04)

## **CHAPTER 2**

### **Fire Department**

#### *Article I Fire Department*

#### **Sec. 3-2-1. Firefighters; duties.**

(a) The members of the Fire Department shall perform all the duties of the Fire Department under the direction and control of the Fire Chief, the assistant chiefs and the captains of their respective companies. They shall wear such uniforms or insignia of office as may be prescribed by the regulations of the Department.

(b) Firefighters employed by the City shall be vested with the authority of a police officer and shall be charged with the duty to enforce the provisions of this Chapter and Chapter 4 of Title VII, including the authority to issue summons and complaint for violations thereof.

(c) The particular duties of all ranks and members of the Fire Department shall be prescribed by the Fire Chief.

(d) Members of the Fire Department are required to devote their entire attention to the service of the City. (1957 Code, §12-5; Ord. No. 4878, 7-13-81)

#### **Sec. 3-2-2. Fire Chief; powers and duties.**

(a) The Chief of the Fire Department or the ranking officer at fires shall have control of persons present at fires, and to that end shall have and exercise all the powers of a captain of police thereat.

(b) He or she may prescribe limits in the vicinity of any fire within which no person may enter, except those who reside therein, members of the Fire Department, policemen and such other persons as may be admitted by the officers of such departments.

(c) He or she shall have power to summon any person present at a fire to aid in extinguishing the fire and removing and protecting property. It shall be unlawful for any person to neglect or refuse to obey such orders. However, no person shall be bound to obey such officer, unless the official character of the officer be known or made known to such person.

(d) He or she shall have power, if in his or her judgment he or she may deem it necessary to order any buildings or structures in close proximity to a fire in progress to be torn down, blown up or otherwise disposed of for the purpose of checking the conflagration, but shall not unnecessarily or recklessly destroy or injure any building or other property. (1957 Code, §§12-1, 12-9, 12-11)

**Sec. 3-2-3. Loitering.**

It shall be unlawful for any person not a member of the Fire Department to meet or loiter in or around a Fire Department building without express permission of the officer in charge. (1957 Code, §12-7)

**Sec. 3-2-4. Apparatus; uses; maintenance.**

Fire apparatus which is the property of the City shall be used only for public purposes, and shall not be used for any private purpose whatever. It shall be kept clean and in perfect working order and ready for fires at all times. (1957 Code, §12-8)

**Sec. 3-2-5. Interfering with hose, hydrant.**

It shall be unlawful for any person other than a duly authorized employee of the City or a duly authorized employee of any public water system in the City to open or draw water from a fire hydrant or any other hydrant, tap or outlet in a public place or park in the City. (1957 Code, §12-12)

**Sec. 3-2-6. Turning water on persons; needlessly handling hose.**

It shall be unlawful for any member of the Fire Department to willfully turn a stream of water, or cause the same to be done, on any person or on any goods or other property susceptible to damage by water, except in case of imminent necessity. It shall be unlawful for any person, whether or not a member of the Fire Department, needlessly to handle the hose or hydrant or other fire apparatus in use. (1957 Code, §12-10)

**Secs. 3-2-7—3-2-20. Reserved.**

Editor's Note: Sections 3-2-7 and 3-2-8 were repealed by Ordinance No. 3564, passed and approved 5-8-72.

*Article II*  
*International Fire Code*

**Sec. 3-2-21. International Fire Code; adoption by reference.**

The 2003 International Fire Code, including the appendices thereto, promulgated and published by the International Code Council, Inc., 5203 Leesburg Pike, Suite 600, Falls Church, Virginia 22041, www.iccsafe.org, hereinafter referred to as the International Fire Code (IFC), is hereby adopted and enacted by reference as the fire prevention code of the City; provided, however, that the following portions or provisions thereof are not hereby adopted: (a) the Preface, (b) the sample form of ordinance adopting the IFC, and (c) Appendix A, Board of Appeals. (1957 Code, §12-18; Ord. No. 5001, 9-13-82; Ord. No. 5294, 2-24-86; Ord. No. 5626, 9-10-90; Ord. No. 6127, 10-15-96; Ord. No. 6359, 10-13-98; Ord. No. 7354 §1, 8-8-05)

**Sec. 3-2-22. Division of Fire Prevention; establishment; supervisor.**

The International Fire Code and this Article II shall be enforced by the Division of Fire Prevention in the Fire Department of the City, which is hereby established and which shall be operated under the supervision of the Chief of the Fire Department. The Chief of the Fire Department may assign one (1) assistant or deputy chief as the head of the Division of Fire Prevention, and such other members of the Fire Department as inspectors as from time to time he or she shall deem necessary. The Chief, the head of the Division of Fire Prevention and such assigned inspectors shall be vested with the authority of a police officer with respect to the enforcement of this Article and the International Fire Code, including the authority to issue a summons and complaint for violation thereof. (1957 Code, §12-19; Ord. No. 5191, 11-12-84; Ord. No. 6127, 10-15-96; Ord. 6359, 10-13-98; Ord. No. 7354 §2, 8-8-05)

**Sec. 3-2-23. Dual coverage; most restricted governs.**

If any section or sections contained in the International Fire Code are also covered by a section or sections of the International Building Code, as the same may be now or hereafter altered, amended or adopted, the most restricted provision or that imposing the highest standard shall govern. (1957 Code, §12-21; Ord. No. 3003, 10-25-65; Ord. No. 5191, 11-12-84; Ord. No. 7354 §3, 8-8-05)

Editor's Note: Sections 3-2-25 and 3-2-26 were repealed by Ordinance No. 4745, passed and approved 5-27-80.

**Sec. 3-2-24. References to other codes.**

(a) Whenever any provision of the International Fire Code contains a reference to the "International Electrical Code" or the "ICC Electrical Code," the reference shall be taken to mean the National Electrical Code, 2002 Edition, as adopted and amended by Chapter 3 of Title IV of this Code.

(b) Whenever any provision of the International Fire Code contains a reference to the "International Plumbing Code" or the "ICC Plumbing Code," the reference shall be taken to mean the Uniform Plumbing Code, 2003 Edition, as adopted and amended by Chapter 4 of Title IV of this Code.

(c) Whenever any provision of the International Fire Code contains a reference to the "International Mechanical Code" or the "ICC Mechanical Code," the reference shall be taken to mean the Uniform Mechanical Code, 2003 Edition, as adopted and amended by Chapter 5 of Title IV of this Code. (Ord. No. 7354 §4, 8-8-05)

**Sec. 3-2-29. Vehicles transporting hazardous materials including flammable liquids; inspections; approval.**

Chapter 27 of the International Fire Code, as adopted by this Chapter, is amended by the addition of the following new Section 2706 to read as follows:

**"Section 2706. Transport of hazardous materials.**

"2706.1. It shall be the duty of the owner of any vehicle used for the delivery of hazardous materials, including flammable liquids, within the City to have such vehicle inspected annually by some agency approved by the Chief of the Fire Department, and to file a report of such annual inspection with the Fire Department before the first day of January each year. It shall be unlawful for any person to operate any vehicle for which an inspection report has not been filed for the current year. The inspection report shall be made on forms furnished by the Fire Department, and shall certify that the vehicle has been inspected and found to be in a safe condition and complies with all structural and safety requirements prescribed by this Chapter and the International Fire Code. Any vehicle which is involved in an accident shall be reinspected and a report of the reinspection filed with the Fire Department before it is put back into service.

"2706.2 A certificate of approval shall be issued by the Fire Department for each vehicle for which an inspection report has been filed. Certificates of approval shall be valid until the first day of January following the date of issuance. The Chief of the Fire Department may refuse to grant such certificate of approval for good cause shown, or may revoke or suspend a certificate for noncompliance with the provisions of this Chapter.

"2706.3 The Chief of the Fire Department, or his duly authorized representative, is authorized and empowered to inspect any vehicle, apparatus or equipment used to transport hazardous materials, including flammable liquids, at any time or place in the City, and shall have the authority to prohibit the use of any vehicle which does not conform to the requirements of this Chapter or the International Fire Code."

(1957 Code, §12-25; Ord. No. 3003, 10-25-65; Ord. No. 5191, 11-12-84; Ord. No. 5294, 2-24-86; Ord. No. 5626, 9-10-90; Ord. No. 6127, 10-15-96; Ord. No. 6359, 10-13-98; Ord. No. 7354 §5, 8-8-05)

**Sec. 3-2-30. Routing; local delivery.**

Chapter 27 of the International Fire Code, as adopted by this Chapter, is amended by the addition of the following new section 2708 to read as follows:

**"Section 2708. Designated routes for hazardous materials.**

"2708.1 It shall be unlawful for any person to drive or operate any tank truck or vehicle, empty, loaded or partially loaded with hazardous materials, including flammable liquids, where such load did not originate in delivery to any point within the City, except upon the routes designated by the Chief of the Fire Department and the Traffic Engineer, and approved by the City Manager. Routes are subject to change as conditions warrant.

"2708.2 It shall be unlawful for any person in making deliveries of hazardous materials, including flammable liquids, within the City to drive or operate any vehicles loaded or partially loaded over or upon any street or alley except on routes approved by the Chief of the Fire Department. A routing map shall be filed with the Fire Department, subject to approval of the Chief of the Fire Department and the Traffic Engineer, and shall include all retail stations on each side of the street handling or selling hazardous material, including flammable liquids, to any consumer.

"2708.3 Trucks making deliveries of hazardous materials, including flammable liquids, within the City shall follow the approved routes as designated in Subsection 2708.2 wherever possible.

"2708.4 During loading and unloading operations, wherever possible, such trucks shall be off the street and not impeding other traffic.

"2708.5 Trucks are prohibited inside any building during delivery operations and all containers shall be filled outside buildings.

"2708.6 When trucks are making deliveries to retailer stations of hazardous materials, including flammable liquids, there shall be a liquid and vapor-tight connection maintained between the truck and the tank or receptacle being filled."

(1957 Code, §12-26; Ord. No. 3753, 9-10-73; Ord. No. 5191, 11-12-84; Ord. No. 5294, 2-24-86; Ord. No. 5626, 9-10-90; Ord. No. 6127, 10-15-96; Ord. No. 6359, 10-13-98; Ord. No. 7354 §6, 8-8-05)

### **Sec. 3-2-31. Existing buildings; effective date.**

Section 102.1 of the International Fire Code relating to the applicability of construction and design provisions to existing buildings is amended to read as follows:

#### **"102.1 Construction and design provisions.**

"The construction and design provisions of this Code shall apply to:

- "1. Structures, facilities and conditions arising after the adoption of this Code.
- "2. Existing structures, facilities and conditions not legally in existence at the time of adoption of this Code.
- "3. Existing structures, facilities and conditions when identified in specific sections of this Code.

"4. Existing structures, facilities and conditions which, in the opinion of the code official, constitute a distinct hazard to life or property.

"5. In addition to the foregoing:

"(a) Whenever an existing building or structure is repaired, renovated or remodeled by any means to an extent of more than twenty-five percent (25%) of its replacement cost at the time of repair, remodeling or renovation, it shall be repaired, renovated or remodeled only in conformity with the provisions of this Code.

"(b) Notwithstanding anything contained in Subparagraph (a) above, in the event the use or occupancy classification of any existing building or structure is materially changed to a use or occupancy class for which the International Fire Code imposes additional or more restrictive requirements than it requires for the former existing use or occupancy, then in such event the building or structure shall be required to comply with the requirements of the International Fire Code applicable to such changed use or occupancy class."

(Ord. No. 5294, 2-24-86; Ord. No. 6127, 10-15-96; Ord. No. 6359, 10-13-98; Ord. No. 7354 §7, 8-8-05)

**Sec. 3-2-32. High-rise buildings; compliance.**

The City Council finds and declares that the requirements of the International Fire Code relating to life safety requirements for existing high-rise buildings have essentially been part of the City's fire prevention code since at least 1986 and that, under the fire prevention code of the City, prior to adoption of the ordinance adopting this Section, such existing buildings had been required to fully comply with all life safety requirements of the fire prevention code by no later than October 13, 2003. Consequently, all life safety provisions contained in the International Fire Code which are applicable to new high-rise buildings shall be and are declared fully applicable to all high-rise buildings existing within the City on the effective date of the ordinance adopting this Section. (Ord. No. 5294, 2-24-86; Ord. No. 6127, 10-15-96; Ord. No. 6359, 10-13-98; Ord. No. 7354 §8, 8-8-05)

**Sec. 3-2-33. International Fire Code; fireworks.**

(a) The introductory paragraph of Section 3301.1 of Chapter 33 of the International Fire Code is amended to read as follows:

"3301.1 Scope. The provisions of this Chapter shall govern the possession, manufacture, storage, handling, sale and use of explosives, explosive materials, fireworks and small arms ammunition. The provisions, requirements and prohibitions set forth in Sections 3-2-51 through 3-5-57 of the Pueblo Municipal Code shall be in addition to, and not in substitution of, provisions set forth in this Chapter. In the event of any direct conflict between such sections of the Pueblo Municipal Code and this Chapter 33, the most restrictive requirement shall apply."

(b) The remainder of Section 3301.1 is unchanged. (Ord. No. 5294, 2-24-86; Ord. 6127, 10-15-96; Ord. No. 6359, 10-13-98; Ord. No. 7354 §9, 8-8-05)

**Sec. 3-2-34. Permit fees for operational and construction permits required by International Fire Code.**

Subsection 105.2 of the International Fire Code, as adopted by this Chapter, is amended by amending subsection 105.2 thereof and by adding new subsections 105.2.5 and 105.2.6 thereto, to read as follows:

**"105.2 Application.** Application for a permit required by this code shall be made to the fire code official in such form and detail as prescribed by the fire code official. Applications for permits shall be accompanied by such plans as prescribed by the fire code official, and payment of the applicable permit fee.

**"105.2.5 Permit fees.** The fees for operational permits, construction permits, and all other services or activities performed by the Fire Department or the fire code official shall be established by resolution adopted by the City Council. Unless specifically provided otherwise in this fire prevention code or Title III of the Pueblo Municipal Code, no fee or charge shall be prorated or refunded.

**"105.2.6 Plan review and inspection fees.** Whenever an application for any building permit pursuant to the International Building Code or Chapter 2 of Title IV of the Pueblo Municipal Code requires plan review for compliance with the International Fire Code, or any inspection or reinspection by the fire code official, the applicant shall be required to pay a plan review and/or inspection fee to the City. Plan review and inspection fees shall be as established in the permit fee resolution adopted by the City Council."

(Ord. No. 8065 §1, 9-14-09)

Editor's Note: Sections 3-2-31 through 3-2-37 were repealed by Ordinance No. 5191, passed and approved 11-12-84.

**Sec. 3-2-38. Smoking in various establishments; rooms permissible; notice.**

(a) Retail Stores. It shall be unlawful for any person to ignite any match or flammable material, or to smoke any cigar, cigarette or pipe, in any retail store where there are sold dry goods, pyroxylin plastics, curtains, draperies, scarves, neckties, dresses, underwear, bedding, bunting, decorating material, linen or similar highly flammable materials or products, except in such room or rooms as may be designated as smoking rooms and used for that purpose. The floor or covering of such rooms shall be incombustible and such rooms shall be well ventilated to the outside of the building. Such smoking rooms shall be approved by the Chief of the Fire Department. "NO SMOKING" signs shall be posted on each floor in such establishments.

(b) Places of Public Assembly. It shall be unlawful for any person to ignite any match or flammable material, or to smoke any cigar, cigarette or pipe in any theater, opera house, auditorium or place of public assembly, except in rest rooms, lounges or offices designated and approved by the Chief of the Fire Department.

(c) Public Elevators. It shall be unlawful to smoke any cigarette, cigar or pipe, or to carry any lighted cigarette, cigar or pipe into any public elevator in the City. "NO SMOKING" signs shall be posted and maintained in all public elevators by the owner or lessee.

(d) Service Stations. It shall be unlawful to smoke around gasoline service stations and garages where gasoline and other flammable fluids are being handled or dispensed. A plainly printed notice of "NO SMOKING" shall be posted in a conspicuous place by the owner or lessee of the service station or garage.

(e) Hotels, etc. Any person who by smoking or attempting to light or smoke cigarettes, cigars, pipes or tobacco in any manner in which lighters or matches are employed who shall in a careless, reckless or negligent manner whatsoever, whether willfully or wantonly or not, set fire to any bedding, carpet, curtain, drapes, furniture, house or household furnishings or other equipment or appurtenances in or to any hotel or other building of like occupancy shall be guilty of a violation of this Code and shall be subject to punishment prescribed in Section 1-2-1. In each sleeping room of all hotels, rooming houses, lodging house and other places of public abode, a plainly printed notice shall be posted in a conspicuous place, by the owner or lessee advising tenants of the provisions of this Section.

(f) Public Conveyances. It shall be unlawful to smoke or carry a lighted cigar, pipe or cigarette on any motor bus or other public conveyance operating on established schedules within the City. A plainly printed notice of "NO SMOKING" shall be posted in a conspicuous place on each transportation vehicle. (1957 Code, §17-79; Ord. No. 5191, 11-12-84; Ord. 6127, 10-15-96; Ord. 6359, 10-13-98; Ord. 7354 §13, 8-8-05)

Editor's Note: Sections 3-2-39 through 3-2-43 were repealed by Ordinance No. 5191, passed and approved 11-12-84.

**Sec. 3-2-50. Open burning; incinerators; ashes.**

(a) No person shall burn or permit to be burned on any premises owned or controlled by him or her, or on any public street, alley or other land adjacent to such premises, any rubbish, waste paper, trash, wood or other combustible material.

(b) No ashes shall be kept or deposited in any part of the City except in a secure, noncombustible room or receptacle constructed of such materials and of such design and so located that ashes deposited or kept therein cannot be blown or carried therefrom by wind, and that no fire can be communicated therefrom to fences, buildings or any combustible material.

(c) For purposes of enforcement of this Section the Fire Department and the Police Department are hereby directed to report all violations hereof to the Health Department and to render to the Health Department such aid and assistance as may be necessary to the enforcement of this Section.

(d) For emergency situations only, the Fire Department and the Health Department may issue a joint permit allowing open burning.

(e) This Section shall not apply to:

- (1) Fires used for the noncommercial preparation of food for human consumption.
- (2) Fires for instructional or recreational purposes.

(f) Nothing contained in this Section shall prohibit the burning of weeds upon land zoned for agricultural use, provided that such burning be done in compliance with all applicable ordinances of the City, state statutes and the rules and regulations of any city or state agency or board. (Ord. No. 3331, 2-9-70; Ord. No. 3680, 3-12-73; Ord. No. 5191, 11-12-84; Ord. 6127, 10-15-96; Ord. 6359, 10-13-98; Ord. 7354 §13, 8-8-05)

### **Sec. 3-2-51. Definitions.**

As used in this Chapter, unless the context otherwise required:

(1) **Fireworks.**

a. *Fireworks* means any article, device or substance prepared for the primary purpose of producing a visual or auditory sensation by combustion, explosion, deflagration or detonation, including, without limitation, the following articles and devices commonly known and used as fireworks, but excluding those devices, articles or substances described in paragraph (1)b below: toy cannons or toy canes in which explosives are used, blank cartridges, the type of balloon which requires fire underneath to propel the same, firecrackers, torpedoes, skyrockets, rockets, bottle rockets, Roman candles, Day-Glo bombs and torches, or other fireworks of like construction and any fireworks containing any explosive or flammable compound, or any tablets or other device containing any explosive substance.

b. *Fireworks* does not include:

1. The following articles, devices or substances which may be commonly known and used as fireworks do not produce an auditory sensation and are not propelled or made airborne by combustion, explosion, deflagration or detonation: smoke-bombs, fountains, flower-towers or similar devices or articles.
2. Toy caps which do not contain more than twenty-five hundredths (.25) of a grain of explosive compound per cap;
3. Sparklers, trick matches, cigarette loads, trick noisemakers, toy smoke devices and novelty auto alarms; and
4. Highway flares, railway fuses, ship distress signals, smoke candles and signaling devices for emergency purposes.

(2) *Manufacturer* includes any wholesaler and any person who manufactures, makes, constructs or produces any fireworks article or device.

(3) *Person* includes an individual, partnership, firm, company, association or corporation.

(4) *Retailer* includes any person who sells, delivers, consigns or furnishes fireworks to another person not for resale.

(5) *Wholesaler* includes any person who sells, delivers, consigns, gives or in any way furnishes fireworks to a retailer for resale. (Ord. No. 4745, 5-27-80; Ord. 6127, 10-15-96; Ord. 6359, 10-13-98; Ord. 7354 §13, 8-8-05)

**Sec. 3-2-52. Unlawful to sell or use certain types of fireworks.**

It shall be unlawful in the City for any person to possess any fireworks, or to offer for sale, expose for sale, sell or have in his or her possession with intent to offer for sale, sell, use or explode any fireworks. (Ord. No. 4745, 5-27-80; Ord. 6127, 10-15-96; Ord. 6359, 10-13-98; Ord. 7354 §13, 8-8-05)

**Sec. 3-2-53. Items not considered fireworks; permits for sale.**

(a) Those items listed in Section 3-2-51 which are not included as fireworks and are sold in any temporary or permanent place of business shall only be sold in a B-3, B-4, I-1, I-2 or I-3 Zone District as defined in Title XVII of this Code; provided, however, that the sale of the same in any temporary or permanent place of business shall be restricted to the period of seven (7) days prior to the Fourth of July in each year, and the use thereof if obtained from a temporary place of business shall be restricted to the hours between 7:00 a.m. and 12:00 midnight on the Fourth of July.

(b) Any person wishing to sell those items described in this Chapter which are not considered fireworks and are sold in any temporary place of business shall obtain a permit therefor. Application for a permit to sell such items for each location shall be made by June 15 of each year. A permit fee of one hundred dollars (\$100.00) shall be charged for each location and shall be paid to the City license officer in the Finance Department. Seventy-five dollars (\$75.00) of the permit fee shall be refunded to the applicant if the site of the sale of these items is cleaned of all stands, refuse and debris constructed or caused by said sale to the satisfaction of the Chief of the Fire Department, or his or her authorized representative, by July 10 of each year. No permit granted hereunder shall be transferable.

(c) No person shall be issued a permit to sell those items described in Section 3-2-51(1)b which are not considered fireworks if he or she has been convicted of any offense involving the possession, sale, transportation or use of fireworks within a period of two (2) years prior to the time application for a permit is made. (Ord. No. 4745, 5-27-80; Ord. No. 5294, 2-24-86; Ord. 6127, 10-15-96; Ord. 6359, 10-13-98; Ord. 7354 §13, 8-8-05)

**Sec. 3-2-54. Regulations and permits for display.**

(a) The requirements of this Chapter shall be in addition to the regulations contained in the Uniform Fire Code previously adopted by Section 3-2-21 of this Code. This Chapter shall govern should there be any inconsistency between the Fire Code and this Chapter.

(b) The Chief of the Fire Department shall have the power to adopt reasonable rules and regulations for the granting of permits for supervised public display of fireworks at any time by fair associations, amusement parks and other organizations or groups of individuals. Such rules and regulations may provide minimum qualifications for persons conducting and supervising a display as pyrotechnic operators. Every such display shall be handled by a qualified operator who shall be approved by the Chief of the Fire Department. Every display shall be of such character and so

located that, in the opinion of the Chief of the Fire Department, such display shall not be hazardous to property or endanger any person.

(c) Any person wishing to conduct a fireworks display shall obtain a permit therefor from the Chief of the Fire Department or his or her authorized representative. Application for a permit shall be made in writing not less than fifteen (15) days prior to the date of display. Application shall be made upon a form adopted by the Fire Chief which shall: identify the applicant; identify the operator who shall conduct and supervise the display; state the qualifications and expertise of the operator; identify the premises where the display will be conducted; and contain a signed written consent of the owner of said premises to the display being conducted upon his or her property. A permit fee of thirty dollars (\$30.00) shall accompany the application and shall be collected by the License Officer in the Finance Department. No permit granted hereunder shall be transferable.

(d) It shall be unlawful to store, house or keep those items described in Section 3-2-51(1)b which are not considered fireworks in any building or structure unless such building or structure is provided with a sprinkler system that is properly constructed and maintained according to the Uniform Fire Code and the Uniform Building Code. (Ord. No. 4745, 5-27-80; Ord. No. 5294, 2-24-86; Ord. No. 6127, 10-15-96; Ord. No. 6359, 10-13-98; Ord. 7354 §13, 8-8-05)

#### **Sec. 3-2-55. Bonds and insurance.**

(a) Any person selling those items not considered fireworks in a temporary place of business, or conducting a fireworks display, shall execute and file with the License Officer a license and performance bond in the penal sum of one thousand dollars (\$1,000.00) naming the City of Pueblo as obligee and conditioned upon full compliance with the provisions of this Chapter.

(b) Any person conducting a fireworks display shall, in addition to a performance bond, also obtain a comprehensive general liability insurance policy to cover injury and damage to persons and property caused as a result of the display. Said policy shall be in amounts of not less than six hundred thousand dollars (\$600,000.00) per occurrence and aggregate for both personal injury, including bodily injury and death, and property damage. (Ord. No. 4745, 5-27-80; Ord. No. 6127, 10-15-96; Ord. 6359, 10-13-98; Ord. 7354 §13, 8-8-05)

#### **Sec. 3-2-56. Interpretation.**

This Chapter shall not be construed to prohibit:

(1) Any person, including a manufacturer, who has first obtained a state license to sell display fireworks, from possessing, offering for sale, exposing for sale, selling or having in his or her possession with intent to offer for sale, or sell, fireworks in any municipality, fair association, amusement park or other organization or group holding a display permit issued as provided in this Chapter, or to the Colorado State Fair and Industrial Exposition Commission or to any county or district fair duly organized under the laws of the State;

(2) Any person from using or exploding fireworks in accordance with the provisions of any display permit issued as provided in this Chapter or as part of a supervised public display at the Colorado State Fair and Industrial Exposition or any county or district fair organized under the laws of the State;

(3) Any resident manufacturer from manufacturing and selling or any resident wholesaler, dealer or jobber from selling at wholesale, such fireworks as are not prohibited under this Chapter, the sale of any kind of fireworks, provided that the same are to be shipped directly out of state in accordance with regulations of the United States Interstate Commerce Commission covering the transportation of explosives and other dangerous articles by motor, rail and water, the use of fireworks by railroads or other transportation agencies for signal purposes or illumination, the sale or use of blank cartridges for a show or theater, signal or ceremonial purposes in athletics or sports, or use by military organizations, or the use of fireworks for agricultural purposes under conditions approved by the City Council;

(4) Any person from possessing, offering for sale, exposing for sale, selling, having in his or her possession with intent to offer for sale or sell, or using or firing toy pistols, toy guns, sparklers or other devices for which caps are manufactured except as provided in this Chapter; or

(5) The importation, purchase, sale or possession of fireworks which are used or to be used solely to prevent damage to crops by animals or birds upon lands zoned for agricultural use, the sale and use of which shall be governed by rules and regulations adopted by the State. (Ord. No. 4745, 5-27-80; Ord. 6127, 10-15-96; Ord. 6359, 10-13-98; Ord. 7354 §13, 8-8-05)

**Sec. 3-2-57. Seizure of fireworks.**

The Chief of Police or his or her authorized agent may seize, take and remove, at the expense of the owner, all stocks of fireworks or combustibles offered or exposed for sale, stored or held in violation of this Chapter. (Ord. No. 4745, 5-27-80; Ord. 6127, 10-15-96; Ord. 6359, 10-13-98; Ord. 7354 §13, 8-8-05)

**Sec. 3-2-58. Unlawful conduct and criminal penalties; revocation of permits; other enforcement.**

(a) It shall be unlawful and a Class 1 municipal offense for any person to knowingly violate, disobey, omit, neglect, refuse or fail to comply with or resist the enforcement of any provision of this Chapter or of the International Fire Code, and, upon conviction thereof, the punishment therefor shall be a fine of not more than one thousand dollars (\$1,000.00) or imprisonment for not more than one (1) year, or both such fine and imprisonment.

(b) It shall be unlawful and a Class 1 municipal offense for any person to refuse or fail to timely comply with any order issued by the Chief of the Fire Department, the head of the Division of Fire Prevention or other designated fire inspector pursuant to the provisions of this Chapter or the International Fire Code, and, upon conviction thereof, the punishment therefor shall be a fine of not more than one thousand dollars (\$1,000.00) or imprisonment for not more than one (1) year, or both such fine and imprisonment.

(c) It shall be unlawful and a Class 1 municipal offense for any person to knowingly make any false statement, representation or certification in any application, record, report, plan or other document filed or required to be maintained pursuant to any requirement of this Chapter or the International Fire Code, and, upon conviction thereof, the punishment therefor shall be a fine of not more than one thousand dollars (\$1,000.00) or imprisonment for not more than one (1) year, or both such fine and imprisonment.

(d) Any permit issued pursuant to the provisions of this Chapter or the International Fire Code may be suspended, terminated or revoked by the Chief of the Fire Department for:

(1) Any of the reasons stated in Section 105.5 of the International Fire Code; or

(2) Any material violation of the terms of said permit or requirements applicable thereto. In addition, the Chief may immediately suspend any permit issued pursuant to Section 3-2-53 of this Chapter upon the arrest of any permittee or any agent or employee of such permittee for possession of fireworks with intent to sell or offer to sell the same.

(e) In the event any owner or occupant of premises within the City shall refuse entry to the Chief or any fire inspector, or if any premises are locked and the Chief or any fire inspector has been unable to obtain permission of the owner or occupant to enter, the Municipal Court is authorized to issue a search warrant authorizing such entry in accordance with the procedures set forth in the Colorado Municipal Court Rules.

(f) In the event that any owner or occupant of premises within the City, or any licensee or permittee, shall fail or refuse to comply with any provision of this Chapter, the International Fire Code or any license or permit issued thereunder, the City may initiate an action for injunctive relief in any court of competent jurisdiction to compel compliance with said Chapter, International Fire Code, license or permit.

(g) The enforcement remedies set forth in this Section and in Section 109 of the International Fire Code are hereby expressly declared to be cumulative, and the exercise of any one (1) or more of them is not dependent upon the exercise of any other remedy, nor does the exercise of any one (1) or more of them constitute any bar or limitation to the exercise of any other.

(h) Subsection 109.3 of the International Fire Code is amended to read as follows:

**"109.3 Violations; abatement.**

"The provisions set forth in Section 3-2-58(a) through (g) of the Pueblo Municipal Code shall govern with respect to remedies and penalties for violation of, or noncompliance with, this code."

(Ord. No. 4745, 5-27-80; Ord. No. 5191, 11-12-84; Ord. No. 6127, 10-15-96; Ord. No. 6359, 10-13-98; Ord. No. 7354 §10, 8-8-05; Ord. No. 7937 §3, 12-8-08)

**Sec. 3-2-59. Board of Appeals.**

Section 108 of the International Fire Code as amended and adopted by the City is hereby deleted in its entirety and amended to read as follows:

"Any person aggrieved by any ruling, decision, interpretation or order of the Fire Chief, the Deputy or Assistant Fire Chief in charge of fire prevention or the Fire Department shall have the right to appeal to the Fire Board of Appeals, which is hereby created. Such Board shall consist of five (5) members who shall be residents of the City qualified by experience or training in fire safety or related matters. The Fire Chief shall be a nonvoting ex officio member and shall act as secretary of the Board. The Board of Appeals shall be appointed by resolution of the City Council

for such terms and upon such conditions as shall be set forth in such resolution. The Board members shall serve at the pleasure of City Council. The Board shall adopt reasonable rules and regulations for conducting its proceedings and shall render all decisions and findings in writing to the Fire Chief, with a duplicate copy to the appellant, and may recommend to the City Council such new legislation as the Board may deem necessary.

"Any aggrieved person appealing any ruling, decision, interpretation or order shall file a written appeal setting forth the grounds and reasons for such appeal with the Fire Chief within ten (10) days from the date of such ruling, interpretation, order or decision which is being appealed. If such notice is timely filed, the Board of Appeals shall set a time and place for a hearing and, by first class mail, postage prepaid, notify the party filing the appeal. The date of the hearing shall be not more than twenty (20) days after the filing of the appeal. The hearing shall be open to the public and all interested persons shall be heard. The Board of Appeals, by majority vote of the members present, shall affirm, modify or reverse any appealed ruling, interpretation, order or decision of the Fire Chief, the Deputy or Assistant Fire Chief for fire prevention or the Fire Department. The Board of Appeals may permit a variance from the strict terms and provisions of this Chapter or the International Fire Code as adopted by the City in order to avoid extreme hardship, provided that such variance can be made without increasing the hazards to the health or safety of persons or property, and further provided that the granting of such variance will not violate the intent and purposes of the fire code. Mere inconvenience to the appellant shall not be grounds for the granting of a variance."

(Ord. No. 5191, 11-12-84; Ord. No. 6127, 10-15-96; Ord. 6359, 10-13-98; Ord. No. 7354 §12, 8-8-05)

**Sec. 3-2-60. Additional modifications to the International Fire Code.**

The following Sections or Subsections of the International Fire Code and Appendices thereto, as adopted by this Chapter, are amended as follows:

(1) The definition of "Fire Apparatus Access Road" in Section 502.1 is amended to read as follows:

**"FIRE APPARATUS ACCESS ROAD.** A road on private property that provides fire apparatus access from a public way to a facility, building or portion thereof. This is a general term inclusive of all other terms such as fire lane, private street, parking lot lane and access roadway."

(2) The definition of "Public Way" in Section 1002.1, Definitions, is amended to read as follows:

**"PUBLIC WAY.** A street, alley or other parcel of land that has been platted, deeded, dedicated or otherwise permanently appropriated to the public for public use or a private roadway subject to a public ingress, egress or access easement."

(3) Section 1002.1, Definitions, is amended by the addition of a new definition for "Emergency Vehicle Access" to read as follows:

**"EMERGENCY VEHICLE ACCESS.** A continuous and unobstructed paved way of ingress and egress from a public way to a development specifically intended for the use of emergency service vehicles and not the general public."

(4) Subsection D102.1 of Appendix D is amended to read as follows:

**"D102.1. Access and loading.** Facilities, buildings or portions of buildings hereafter constructed shall be accessible to fire department apparatus by way of a public way or an approved fire apparatus access road with an asphalt, concrete or other approved driving surface which shall comply with the most recent *Roadway Classification Design Standards and Policies* adopted by City Council Resolution No. 10264 pursuant to the authority of Section 12-4-7 of the Pueblo Municipal Code, as amended."

(5) Subsection D103.1 of Appendix D is amended to read as follows:

**"D103.1 Fire apparatus access roads.** Fire apparatus access roads shall be designed and constructed in accordance with this Appendix D and all other applicable requirements of the International Fire Code. Where a fire hydrant is located on a fire apparatus access road, the minimum road width shall be twenty-six (26) feet (7925 mm). See Figure D103.1."

(6) Paragraph 1 of Subsection D103.5 of Appendix D is amended to read as follows:

"1. The minimum gate width shall be as determined by the Fire Chief."

(7) Figure D103.1 of Appendix D is amended by the deletion of the 70' diameter cul-de-sac so as to appear as follows:

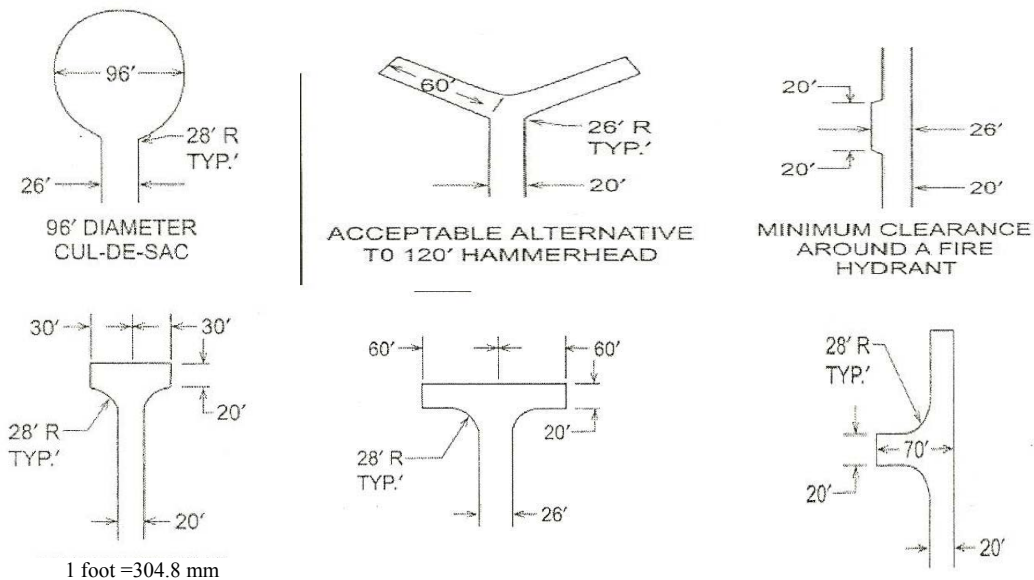

FIGURE D103.1  
DEAD-END FIRE APPARATUS ACCESS ROAD TURNAROUND

End of Figure D103.

(8) A new Subsection D103.7 is hereby added to Appendix D to read as follows:

**"D103.7 Public roadways.** All public roadways shall be designed and constructed in accordance with the *Roadway Classification Design Standards and Policies* adopted by Resolution No. 10264 and the *Standard Construction Specifications and Standard Details* adopted by Resolution No. 10129."

(9) Subsection D104.2 and D104.3 of Appendix D are amended to read as follows:

**"D104.2 Buildings or facilities or aggregate development exceeding 62,000 square feet in area or generating more than 2,000 vehicle trips per day.** Buildings or facilities or aggregate development having a gross building area of more than 62,000 square feet (5,760 m<sup>2</sup>) or generating more than two thousand (2,000) vehicle trips per day shall be provided with two (2) separate and approved fire apparatus access roads within the site and shall provide unimpeded access from two (2) separate directions via public roadways.

**"D104.3 Remoteness.** Where two (2) fire apparatus roads are required, they shall be placed a distance apart equal to not less than one-half of the length of the maximum overall diagonal dimension of the property or area to be served, measured in a straight line between accesses."

(10) Subsection D106.1 of Appendix D is amended to read as follows:

**"D106.1 Multiple-family residential projects having more than 100 dwelling units or generating more than 600 vehicle trips per day.** Multiple-family residential projects having more than one hundred (100) dwelling units or generating more than six hundred (600) vehicle trips per day shall be equipped throughout with two (2) separate and approved fire apparatus access roads and shall provide unimpeded access from two (2) separate directions via public roadways."

(11) Subsection D107.1 of Appendix D is amended to read as follows:

**"D107.1 One- or two-family dwelling residential developments.** Developments of one- or two-family dwellings where the number of dwelling units exceeds sixty (60) or the development generates more than six hundred (600) vehicle trips per day shall provide unimpeded access from two (2) separate directions via public roadways.

**"EXCEPTIONS:**

"1. Where there are between sixty (60) and one hundred (100) dwelling units on a single public or private access way and all dwelling units are protected by approved residential sprinkler systems, public access from two (2) directions shall not be required; however, a secondary emergency vehicle access shall be required.

"2. Planned, sequential developments that will connect with future public roadway networks of the City shall be allowed to construct up to two hundred (200) dwelling units or generate up to two thousand (2,000) vehicle trips without providing two (2) separate fire apparatus access roads or public roadways to the site."

(Ord. No. 7354 §11, 8-8-05)